

W. N. MANNING.  
Pivot Turning Attachment.

No. 199,217.

Patented Jan. 15, 1878.

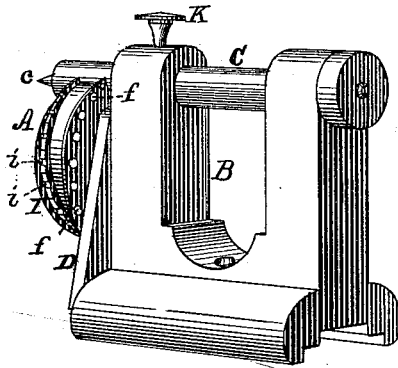

FIG. 2.

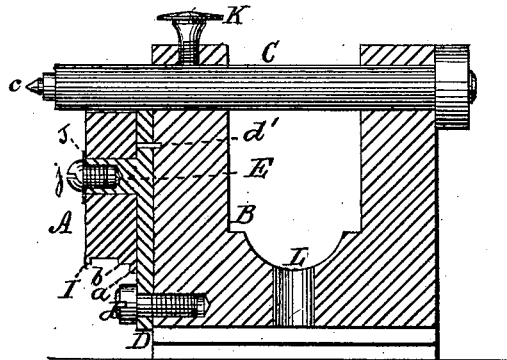

FIG. 3

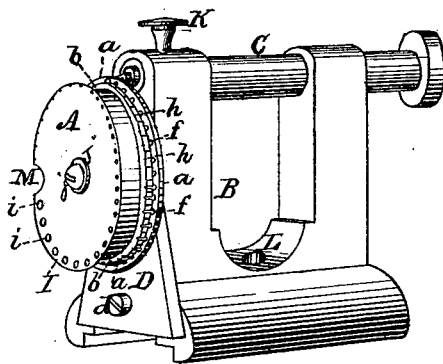

FIG. 1.

WITNESSES.

*Chas. F. Perkins*  
*J. H. Pendergast*

INVENTOR.

*Wm. N. Manning*  
*by Chas. F. Perkins*  
*his attorney.*

# UNITED STATES PATENT OFFICE.

WILLIAM N. MANNING, OF ROCKPORT, MASSACHUSETTS.

## IMPROVEMENT IN PIVOT-TURNING ATTACHMENTS.

Specification forming part of Letters Patent No. 199,217, dated January 15, 1878; application filed May 31, 1877.

*To all whom it may concern:*

Be it known that I, WILLIAM N. MANNING, of Rockport, in the county of Essex and Commonwealth of Massachusetts, have invented a Watch and Clock Maker's Pivot-Turning Attachment, of which the following is a specification:

The object of my invention is to provide a turning-gage for turning down and gaging the size and length of watch-pivots and other parts of watches, and for similar work where great accuracy is required, to be attached to a watch-maker's lathe.

In the drawing, Figure 1 represents a perspective view of the tail-stock of a watch-maker's lathe with my invention attached, looking from the front, and in position for use. Fig. 2 represents the same looking from the rear, with the back-center so arranged that the attachment is not in use; and Fig. 3, a central longitudinal section of the same.

A is my pivot-turning gage, attached to the tail-stock B of a watch-maker's lathe. C is the back-center of the lathe; D, a plate screwed at *d*, and pinned at *d'* to the tail-stock B, with a stud, E, Fig. 2, on which the gage A may be revolved. *ff* are holes for receiving the point *c* of the back-center C, placed at regular intervals of about three-sixteenths of an inch, entirely around and through a flange, *a*, on the inner side of the gage, which flange is about three-sixteenths of an inch above the periphery of the gage.

On the periphery of a lower flange, *b*, about three-sixteenths of an inch above the periphery of the gage, is a series of flat sections, *h h*, Fig. 1, the use of which is to prevent the file from cutting any deeper than the work requires.

I is a flange on the outer edge of the periphery of the gage, and rising about three-sixteenths of an inch above it, and having a series of graduated holes, *ii*, placed opposite the holes *ff*, to receive the work to be operated on. K is a screw to secure the back-center C. At L is to be placed a screw to secure the tail-stock.

J is a collar placed around the stud E, and *j* a screw, the use of the collar and screw be-

ing to secure and give the proper tension to the gage on the stud E.

The operation of my invention is as follows: I secure the pinion, staff, or other piece of work to be operated on to the arbor of the head-stock of the lathe, which is usually done by chucks. I find the size of this piece of work, and turn the gage until the same size of the holes *ii* is at the top. I then place the point *c* of the back-center in one of the holes *ff* directly opposite, and secure the back-center by the screw K. This will bring the hole *i* of the required size in line with the work to be done. I then move the tail-stock up to the work until the article to be operated on has entered the hole *i* as far as required, and secure the tail-stock by a screw at L. I then set the lathe in motion and use the pivot-file on the work, guided by the flange I, until it is brought to the required size. If extra length should be required, move the tail-stock up again. If a fine pivot is required, or a second turning down of a part of the length is needed, revolve the gage again to the size of hole *i* wanted, and operate as before.

The gage A is to be so tempered that the file will not damage or affect it. It will be seen that when the gage is once made correct it must always center the same.

When the lathe is wanted for other work, turn the gage A until the back-center C will pass through the opening M, Fig. 1, and the gage is entirely out of the way. This may be seen illustrated in Figs. 2 and 3.

My gage may be applied to a great variety of work, among which may be mentioned making many small screws of exact size and length. It supplies the place of all pivot appliances, and has the advantages of being adapted to the common lathe. It has a great variety of sizes of holes and stops, and is a sure means of enabling the operative to turn his work to the required length and size. It will save time, do the work much more accurately, and is always ready for use.

Having thus described my invention, what I claim as new, and desire to secure by Letters Patent, is—

1. The gage-wheel A, constructed substan-

tially as shown, with the inner flange *a* perforated at regular intervals with holes *f*, lower flange *b*, with flat sections *h* on its periphery, and outer flange *I*, having a series of graduated holes, *i*, as and for the purposes described.

2. The gage-wheel *A*, constructed with the recess or opening *M*, in combination with the back-center *C*, substantially as and for the purposes described.

3. In combination with the gage-wheel *A*, the plate *D*, with stud *E*, for securing the gage-wheel to the tail-stock of a lathe, as described.

4. The combination of tail-stock *B*, back-center *C*, and clamping-screws *K L* of a lathe, plate *D*, with pin *d'* at its back, and stud *E*, double perforated flanged gage-wheel *A a b I*, screws *d j*, and collar *J*, all constructed, arranged, and adapted to operate substantially as and for the purposes described.

WILLIAM N. MANNING.

Witnesses:

ALFRED PARSONS,  
SAM. FERRY.